

Overview and Identification

Humans respire Volatile Organic Compounds (VOCs) as well as CO₂. The BAPI sensor measures these VOCs and indicates when a space is occupied just as well as a CO₂ sensor.

The advantage of the VOC sensor is that it measures air contaminants from other sources besides respiration, such as building materials, cleaners, perfumes and furniture and carpet off-gassing.

Using this sensor for Demand Controlled Ventilation then is a way of achieving true indoor air quality, rather than just CO₂ dilution. A further benefit is that it requires no additional work on your part. That's because the sensor converts the VOC reading to a CO₂ equivalent level. This lets you use ASHRAE's CO₂-based VRP schedule to ventilate.

The Duct Sensor samples duct air using an aspiration tube, while the Rough Service unit features a ventilated BAPI-Box and is ideal for areas such as outdoor air plenums, equipment rooms, green houses and warehouses. The VOC level is indicated as "Good, Fair or Poor" by three discrete green, yellow and red LED's on the front of the unit. If the output reaches 2,000 PPM, the red LED will begin to flash because it has hit its maximum output.

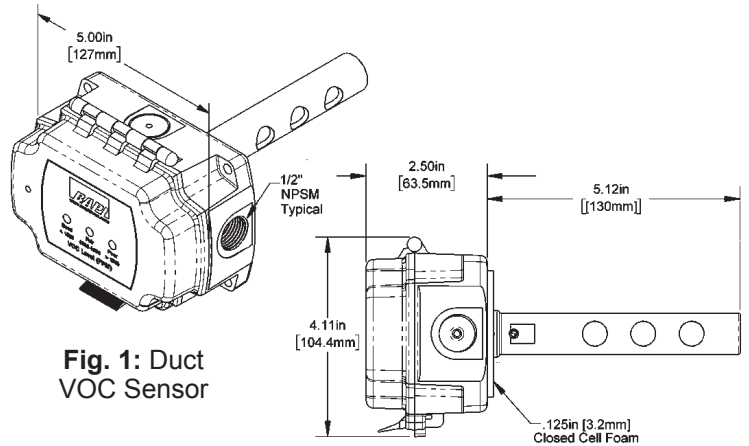

Fig. 1: Duct VOC Sensor

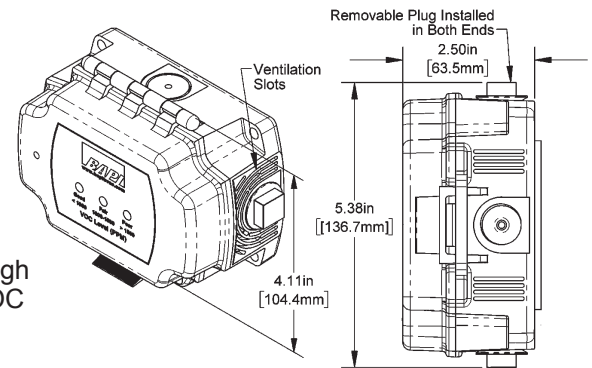

Fig. 2: Rough Service VOC Sensor

Mounting Template

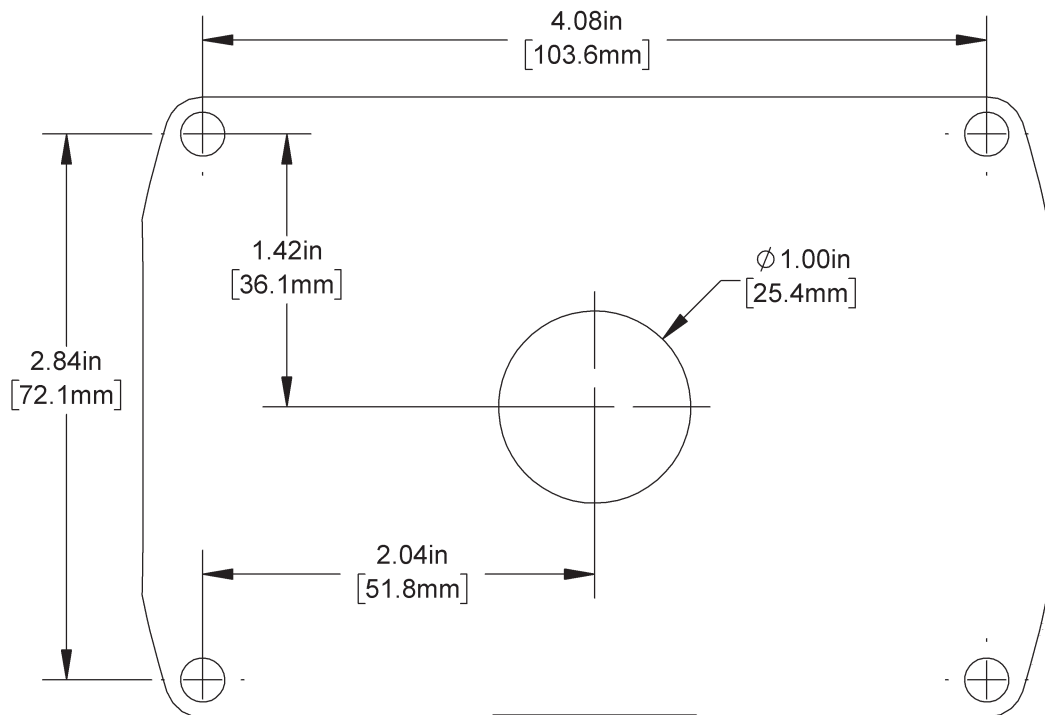

Fig. 3: Mounting Template, Actual Size

Specifications subject to change without notice.

Rough Service Unit Mounting

Mount the Rough Service sensor on a solid, non-vibrating surface. Wall mounting in a room should be 3 to 5 feet above floor level. The Rough Service VOC transmitter may be mounted in any orientation. If you are mounting inside a duct or mixing box, mount with the latch facing into the moving air.

Refer to local codes for further sensor/transmitter installation information. See BAPI's "Coverage Area" Application Note for further mounting recommendations. To get to this application note, go to www.bapivac.com, select "Resource Library" from the banner. Click on "Application Notes" then scroll down the page to the heading "Air Quality Related" and chose "Coverage Area and Mounting Recommendations for BAPI Indoor Air Quality Sensors".

1. BAPI recommends #10 (provided) screws of a type and length suitable for the mounting surface. Four mounting screws keeps the box from twisting, twisting may prevent the latch from operating properly. A pilot-hole makes mounting easier. Use the enclosure mounting feet to mark the pilot-hole locations.
2. Snug up the screws so that the foam backing is depressed but do not over-tighten or strip the screw threads.
3. Place the provided #6 screws into the holes on each side of the lid latch to make the cover tamper resistant.

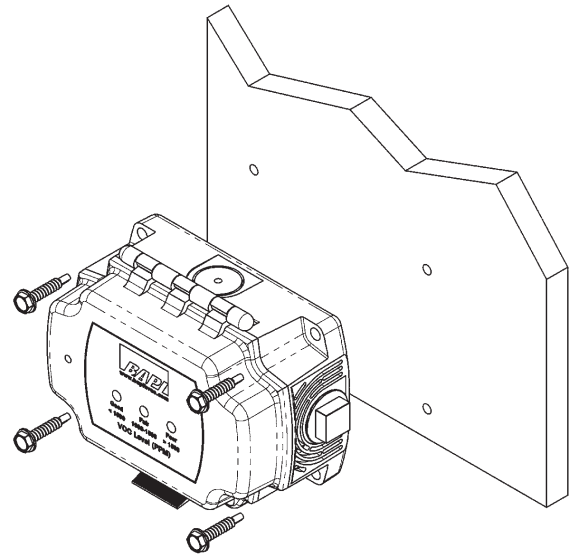

Fig. 4: Mounting the Rough Service sensor to a wall

Duct Unit Mounting

1. BAPI recommends placing the sensor in the middle of the duct wall, away from stratified air, to achieve the best reading. The unit should also be a minimum of 3 duct diameters from an elbow, damper or other duct restriction.
2. Drill a 1" hole for the aspiration probe.
3. Position the box so that airflow is directly into the holes on one side of the aspiration probe. There are no upstream or downstream holes, the air direction is not important.
4. Mount the enclosure to the duct using BAPI recommended #10 screws (provided) through a minimum of two of the mounting feet on opposite corners. A 1/8" pilot screw hole in the duct makes mounting easier. Use the enclosure mounting feet to mark the pilot-hole locations.
5. Snug up the screws until the foam backing is compressed about 50% to prevent air leakage but do not over-tighten.
6. Use the provided #6 screws to secure the cover for IP66 rating.
7. BAPI recommends sealing the conduit opening with fiberglass insulation.

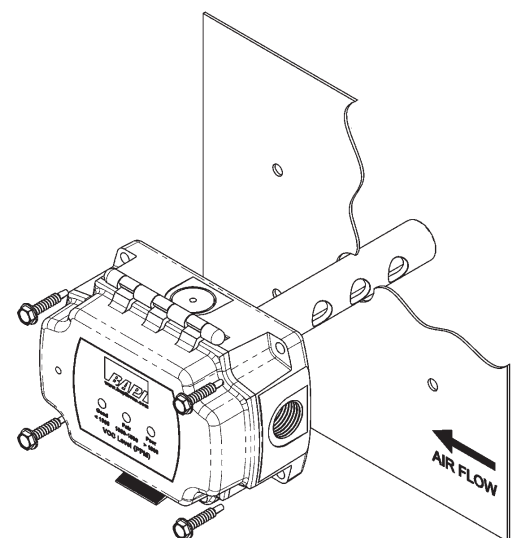

Fig. 5: Duct unit mounting

Termination

BAPI recommends using twisted pair of at least 22AWG and sealant filled connectors for all wire connections. Larger gauge wire may be required for long runs. All wiring must comply with the National Electric Code (NEC) and local codes.



BAPI recommends wiring the product with power disconnected. Proper supply voltage, polarity and wiring connections are important to a successful installation. Not observing these recommendations may damage the product and void the warranty.

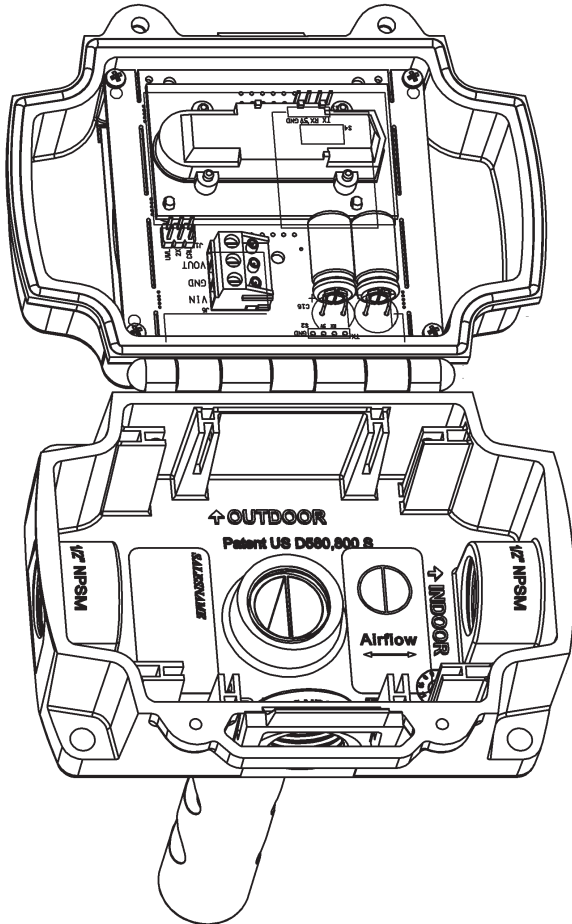

Fig. 6: Circuit board on open unit

Terminal	Description
VIN.....	Power, referenced to GND 12 to 24 VDC, 35 mA Peak 18 to 24 VAC, 4 VA Peak
GND.....	To controller Ground [GND or Common]
VOUT.....	Voltage Output, VOC Signal (0 to 2,000 ppm), referenced to GND

The VOC outputs may be field configured for 0 to 5 VDC or 0 to 10 VDC outputs at any time. Set the jumpers on J1 as shown in Figures 7 and 8.

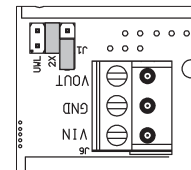

Fig. 7: J1 set for 0 to 10 VDC output

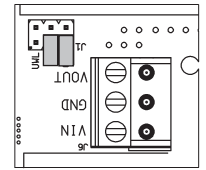

Fig. 8: J1 set for 0 to 5 VDC output

Keeping the Enclosure Air Tight After Termination

For the sensor to work correctly, the wiring entrance must remain air tight. If the VOC transmitter is mounted to a hollow wall and wired through its back, or wired with conduit, it is possible that a draft of clean air may fill the enclosure through the wiring opening. This draft may prevent the unit from measuring ambient VOCs. BAPI recommends either a liquid-tight fitting or plugging the conduit at the enclosure.

- **Liquid-Tight Fitting** – BAPI’s Liquid-Tight Fitting (BA/LTF) allows wire cables of 0.1 to 0.3 inch outside diameter to enter the box. Tightening the collar onto the wire cable keeps the wiring entrance air tight.

- **Conduit** – Included with the VOC transmitter is a foam plug to seal the ½ inch EMT. Place the wires into the plug as shown in Fig. 9 and then insert the plug into the conduit sealing the conduit.

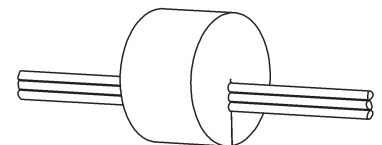

Fig. 9:
Wires Through Foam Plug

Sensor Start-Up

Do not set the control parameter to a VOC limit until the VOC sensor has been installed for a week. The first few days of install may provide different readings compared to several days later.

At each power up, the sensor enters the start-up period for 15 minutes. The VOC output will follow the timing shown in Figure 10. During the start-up period, an optional verification/commissioning test, described below, may be performed. This test is not mandatory. It is necessary only if building commissioning requires sensor verification or if verification of VOC output is required for later troubleshooting.

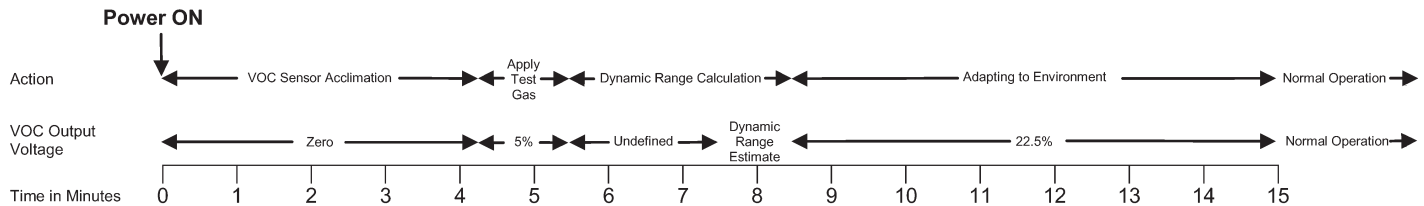

Fig. 10: Sensor Start-up Timeline

Optional Sensor Performance Verification and Commissioning

BAPI's VOC sensor contains an adaptive, self adjusting, Volatile Organic Compound (VOC) sensor element that provides a CO₂ equivalent control signal output. When incorporated into a control strategy based on ASHRAE's Demand Control Ventilation algorithm, ventilation using this sensor will achieve true indoor air quality and not just CO₂ dilution.

The fundamental performance criterion of the VOC sensor element is its dynamic sensing range. The VOC sensor element requires a minimum dynamic range of 30% for proper operation. During BAPI's verification/commissioning test, the dynamic range is tested.

BAPI recommends installing the sensor and powering it for at least 48 hours before the first verification test is performed. BAPI further recommends ventilating the space such that the sensor reads 750 ppm or less CO₂ equivalent before any verification test is performed. Wait at least one hour before repeating the test.

1. Start Automatic Verification/Commissioning Test

- Remove sensor power for at least one minute and reapply. The VOC sensor will set the VOC output to zero volts. (Power ON in Fig. 10)
- Wait four minutes fifteen seconds.
- The VOC sensor will set the VOC output voltage to 5% of full scale (0.25 VDC for 0 to 5 VDC, 0.5 VDC or 0 to 10 VDC outputs).
- The 5% output voltage confirms that the VOC sensor is in its verification/commissioning test. (Apply Test Gas in Fig. 10.)

2. Apply Verification Stimulus

- Apply the stimulus gas during the first minute after the output voltage is set to 5% (See Stimulus Preparation and Application section on next page).
- Read and record the VOC output voltage approximately 2 to 4 minutes following the stimulus gas application to determine the dynamic range measurement. (Dynamic Range Estimate period in Fig. 10)
- Use the graph in Fig. 12 to determine dynamic range.

3. Termination of Verification Mode

- For the last 7 minutes of the start-up period, the sensor adapts to its ambient environment. The VOC sensor will maintain its output voltage at 450 ppm CO₂ equivalent.
- At 15 minutes the VOC sensor will terminate the start-up period and begin normal operation.
- The VOC output will now report the VOCs present as CO₂ equivalents.

4. Result Analysis and Recommendations

The VOC algorithm requires a dynamic range of greater than 30% for proper operation. Sensors reporting a dynamic range of 30% or less should be considered for replacement. (See Fig. 12)

Stimulus Preparation and Application for Dynamic Range Testing

Place 50ml of Isopropyl Alcohol (70% minimum) into a 200ml bottle (2oz in an 8oz bottle) with stopper and allow to reach room temperature (65° to 80°F, 18° to 27°C), a minimum of 15 minutes.

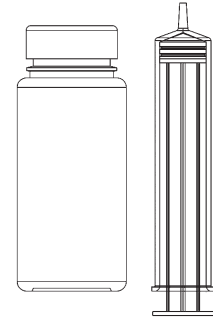

Fig. 11: Alcohol Bottle and Syringe included in the VOC Verification Kit (BA/VOC-KIT)

1. Using a medical grade syringe, remove the stopper from the alcohol bottle, place the tip of the syringe at least half-way into the bottle and withdraw a 60 ml sample of the ALCOHOL VAPOR. (NO LIQUID)
2. Replace the stopper on the alcohol bottle.
3. Place the end of the syringe under, or into the bottom ventilation slot of the VOC monitor's housing.
4. Empty the syringe into the sensor using one continuous motion. Compare the sensor output to the Dynamic Range chart below to verify acceptable operation. Sensors reporting a dynamic range of 30% or less should be considered for replacement.

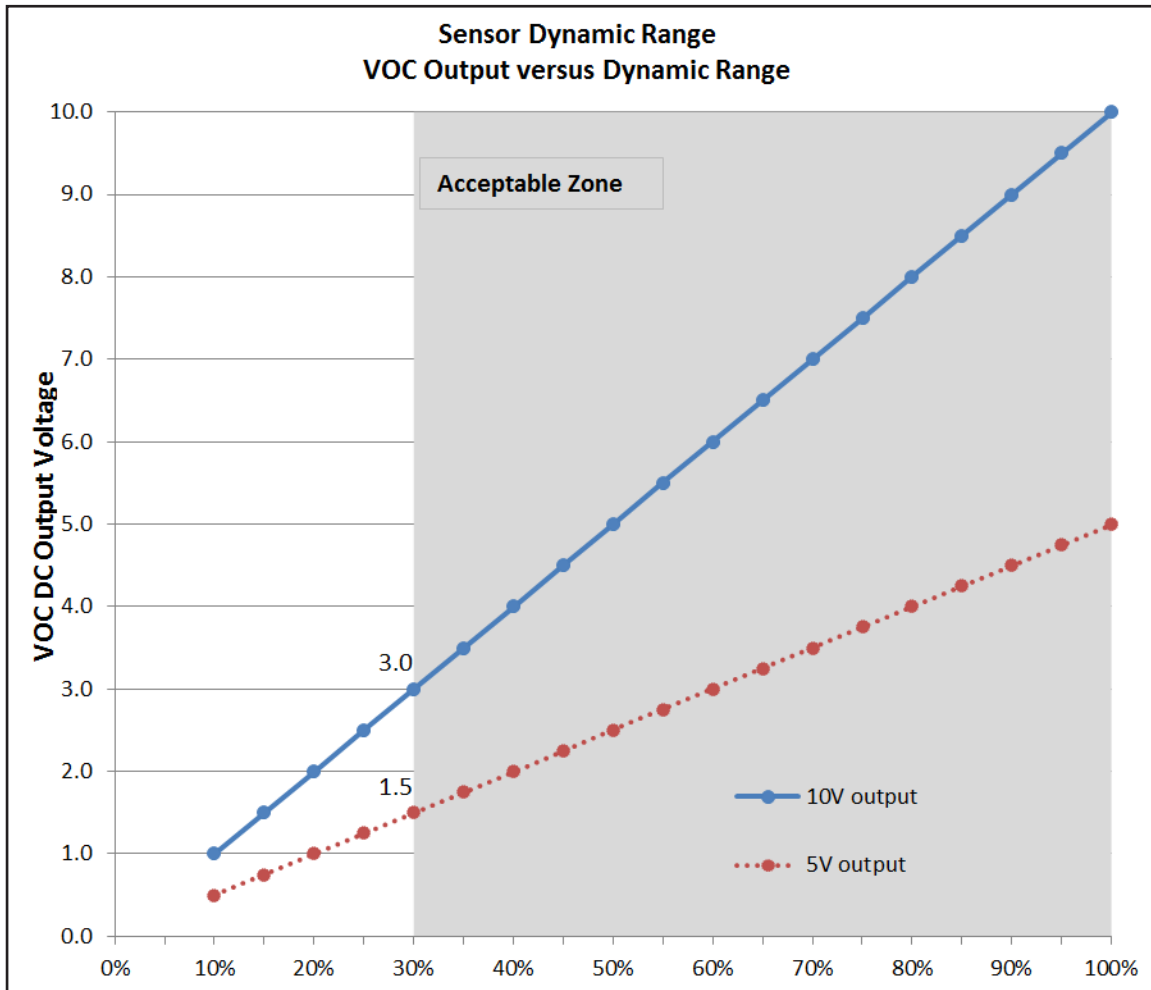

Fig. 12: Acceptable Dynamic Range Output Graph



VOC Duct and Rough Service Sensor

Installation & Operating Instructions

40699_ins_VOC_3LED_BB

rev. 06/05/18

Diagnosics

Possible Problems:

General Troubleshooting

Possible Solutions:

- Determine that the input is set up correctly in the controller and BAS software.
- Check wiring at the sensor and controller for proper connections. If there is corrosion on any terminations, clean off the corrosion, re-strip the interconnecting wire and reapply the connection. In extreme cases, replace the controller, interconnecting wire and/or sensor.
- Label the VOC sensor wire terminals at the sensor and controller ends. Disconnect the wires and measure the resistance from wire-to-wire with a multimeter. The meter should read greater than 10 Meg-ohms, open or OL depending on the meter. Short the wires at one end and measure the resistance from wire-to-wire at the other end. The meter should read less than 10 ohms (22 gauge or larger, 250 feet or less). If either test fails, replace the wire.
- Check the power supply and controller voltage supply.
- Disconnect sensor and check power wires for proper voltage (see power specs).

Incorrect VOC Reading

- Wait 15 minutes after a power interruption.
- Check all software parameters.
- Determine if the sensor is exposed to an external environment different from the room (conduit draft).

Specifications

Power:

12 to 24 VDC, 35 mA Peak
18 to 24 VAC, 4 VA Peak

VOC Sensor:

Micro-machined Metal Oxide

Mounting:

Duct or Surface Mount - screws provided

VOC Detection Range:

0 to 2,000ppm CO₂ Equivalent, Analog Output

Response Time:

Less Than 60 Seconds (after start-up)

Start-up Time:

15 minutes

Operating Environment:

32 to 122°F (0 to 50°C)
5 to 95%RH non-condensing

Analog Outputs:

0 to 5, or 0 to 10VDC >4KΩ impedance

LED VOC CO₂ Equivalent Indicator:

Good, Green < 1,000 ppm
Fair, Yellow = 1,000 to 1,500 ppm
Poor, Red > 1,500 ppm

Material:

ABS Plastic, Material Rated UL94V-0

Certifications:

RoHS

Warranty Period:

Five years from manufacture date

Specifications subject to change without notice.